



# AUTOMATIC EMERGENCY BACKUP SUMP PUMP SYSTEM

MODEL #STBB100

Español p. 13

BasementSentry.com

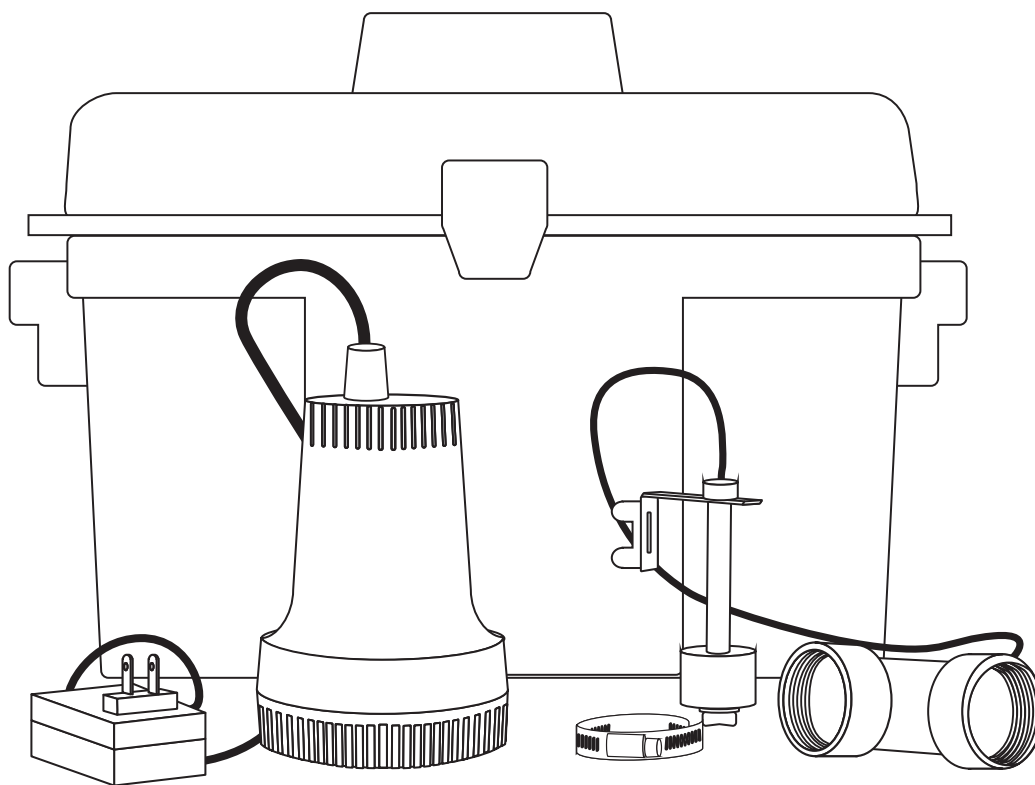

## ATTACH YOUR RECEIPT HERE

Purchase Date \_\_\_\_\_



Questions, problems, missing parts? Before returning to your retailer, call our customer service department at 1-800-742-5044, 7:30 a.m. - 5:00 p.m., EST, Monday - Friday.

## PACKAGE CONTENTS

	DESCRIPTION	QUANTITY
A	12V Pump	1
B	Battery Box	1
C	Switch	1
D	Charger	1
E	90° Elbow	1
F	Pipe clamp	1

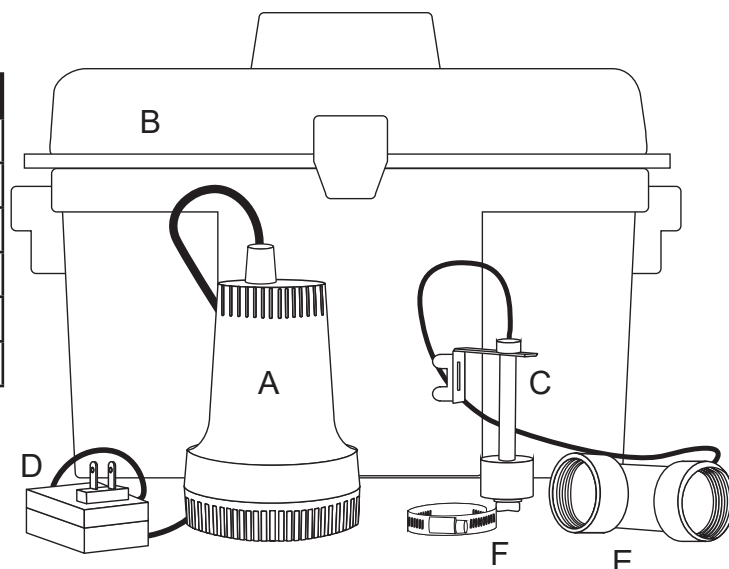

## SAFETY INFORMATION

Please read and understand this entire manual before attempting to assemble, operate, or install the product.

## DANGER

- **RISK OF CHEMICAL BURNS.**

Battery acid is corrosive. Do not spill on skin, clothing or battery charger. Wear eye and head protection when working with battery. Connect and disconnect DC output terminals only after removing the charger from the AC outlet. Never allow the DC terminals to touch each other.

- **FIRE/EXPLOSION HAZARD.**

Keep sparks and flame (pilot light) away from battery.

- **FIRE/EXPLOSION HAZARD.**

Pump only clear water. Do not pump flammable or explosive fluids such as gasoline, fuel oil, kerosene, etc. Do not use in a flammable and/or explosive atmosphere. Failure to follow these warnings could result in death or serious injury and/or property damage.

- **RISK OF ELECTRIC SHOCK.**

These pumps have not been investigated for use in swimming pool or marine areas.

- **RISK OF ELECTRIC SHOCK.**

Always disconnect power source before attempting to install, service, or maintain the pump. Never handle a pump with wet hands or when standing on wet or damp surface or in water. Fatal electrical shock could occur.

- **RISK OF ELECTRIC SHOCK.**

Keep pump out of reach of children.

- **PERSONAL INJURY OR PRODUCT DAMAGE MAY RESULT.**

Failure to comply with instructions and designed operation of this product may void warranty. Attempting to use a damaged pump can result in property damage, serious personal injury and/or death.

## **WARNING**

- **ELECTRICAL SHOCK ALERT.**  
Do not disassemble the motor housing. The motor has NO repairable internal parts and disassembly may cause dangerous electrical wiring issues.
- **ELECTRICAL SHOCK ALERT.**  
Before installing this product, have the electrical circuit checked by an electrician to ensure proper grounding. All electrical installations must conform to the National Electric Code and all local codes.
- **ELECTRICAL SHOCK ALERT.**  
Connect the AC adapter to a properly-grounded 115 volt circuit equipped with a Ground Fault Circuit Interrupter (GFCI) device. Make sure the electrical supply circuit is equipped with fuses or circuit breakers with a minimum capacity of 15 amps.
- **ELECTRICAL SHOCK ALERT.**  
Never use an extension cord.
- **ELECTRICAL SHOCK ALERT.**  
Do not remove or replace the power cord.
- **ELECTRICAL SHOCK ALERT.**  
Protect electrical cord from sharp objects, hot surfaces, oil, and chemicals. Avoid kinking the cord.
- **ELECTRICAL SHOCK ALERT.**  
Do not lift pump by the power cord.
- **PERSONAL INJURY ALERT.**  
Do not touch an operating motor housing. The motor is designed to operate at high temperatures.
- **PERSONAL INJURY ALERT.**  
Release all pressure and drain all water from the system before servicing any component.
- **PERSONAL INJURY ALERT.**  
Secure discharge line before starting pump. An unsecured discharge line can cause personal injury and/or property damage.
- **PERSONAL INJURY ALERT.**  
Wear safety glasses at all times when working with pumps.
- **PROP65 WARNING FOR CALIFORNIA RESIDENTS:**  
Cancer and Reproductive Harm – [www.P65Warnings.ca.go](http://www.P65Warnings.ca.go)

## **CAUTION**

- **PERSONAL INJURY OR PRODUCT DAMAGE MAY RESULT.**  
The AC adapter operates on 115 volts. Make certain that the power source conforms to the requirements of your equipment.
- **PRODUCT DAMAGE MAY RESULT.**  
The continuous operating water temperature for this pump must not exceed 104°F (40°C).
- **PRODUCT DAMAGE MAY RESULT.**  
This pump is designed to pump water only. It has not been evaluated for pumping chemicals or corrosive materials. This pump is not designed for pumping effluent or sewage and should not be used in applications involving salt water or brine.
- **PRODUCT DAMAGE MAY RESULT.**  
Inspect the pump regularly for damage and perform routine maintenance as needed. Remove any debris that may build up around the float.
- **PRODUCT AND/OR PROPERTY DAMAGE MAY RESULT.**  
This pump is not designed for continuous operation.

## PREPARATION

---

**Estimated Installation Time:** 2-4 hours

**Materials required for assembly:** Deep-cycle marine battery, discharge piping and fittings (PVC, poly pipe or galvanized steel), 'Y' pipe, 1-1/2-in 45° elbow, 1-1/2-in check valve, 1-1/4" MNPT x 1-1/2" PVC socket adapter and 2-step PVC glue system (primer and sealer).

MODEL	SPECIFICATIONS			
	PERFORMANCE IN GALLONS PER MINUTE			
	0 FT.	5 FT.	10 FT.	14 FT.
STBB100	29	20	10	Shut Off

## GENERAL PUMP INFORMATION

---

This pump is designed to be installed in a sump basin along with a primary, 115V sump pump for removing clear drain water. It is not a substitute for a primary sump pump. It is designed to temporarily backup the primary sump pump in the event of a power outage or 115V pump failure.

The sump basin must be at least 18-in deep by 14-in diameter.

This system is designed to work with a deep-cycle marine battery, either a flooded lead-acid battery or a sealed, maintenance-free lead-acid battery. Use of an automobile battery instead of a deep-cycle marine battery in this system will significantly reduce pump performance. Automobile batteries are not designed for this type of application and will not stand up to repeated charge and discharge cycling.

Both the primary pump and DC backup pumps will require check valves in the discharge pipes for proper operation.

**NOTE:** Pump must be submerged in water before operation. Running the pump dry will cause damage and void the warranty.

**NOTE: The alarm will sound after connecting the battery. It will continue to sound until all connections are made and the float switch is in the down position.**

The pump will continue to run for an additional 10 seconds after the float has been lowered. The alarm will continue to sound while the pump is working.

Place the battery in a cool, dry, well-ventilated area on a shelf or protective plywood board. If a carbon monoxide (CO detector) is installed in the same area as the DC pump system, it must be at least 15 ft. away from the battery in order to avoid nuisance CO alarms. Refer to CO detector installation guidelines for more information.

## INSTALLATION INSTRUCTIONS

**NOTE:** Install the battery backup system when the primary pump is not needed. Read instructions and prepare all supplies before beginning installation.

1. Verify that the existing 115V sump pump is in good working order. It is best to use a primary sump pump with a vertical float switch. Pumps with tethered float switches require more space and may interfere with the operation of the backup sump pump switch.

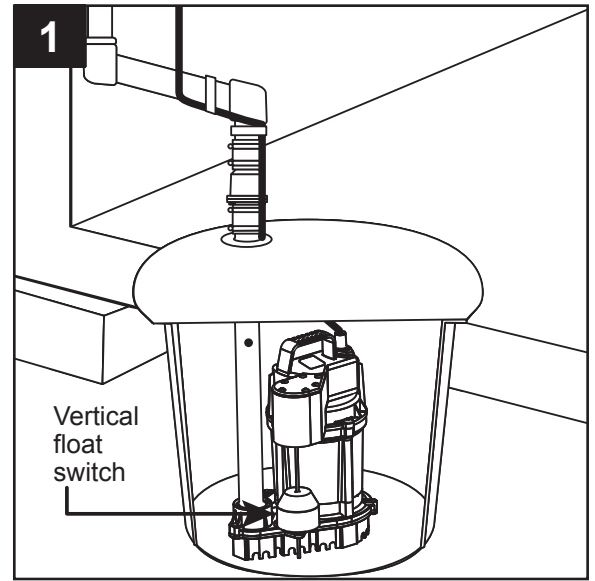

2. Manually operate the primary sump pump to remove as much water as possible from the basin. Do not let the pump run dry.

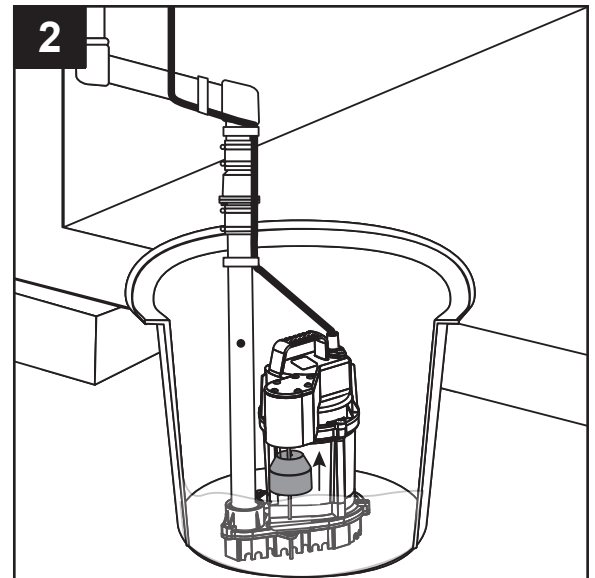

3. Disconnect the primary sump pump from power source before installing the DC pump.

**WARNING:** Never handle a pump with wet hands or when standing on wet or damp surface or in water. Fatal electrical shock could occur.

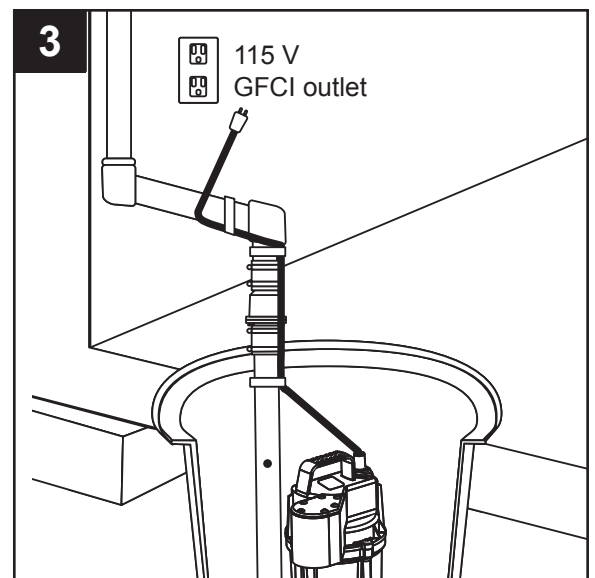

## INSTALLATION INSTRUCTIONS

4. Remove any dirt or accumulated debris from the sump pit and surrounding area. Clean out the vent hole in the discharge pipe.

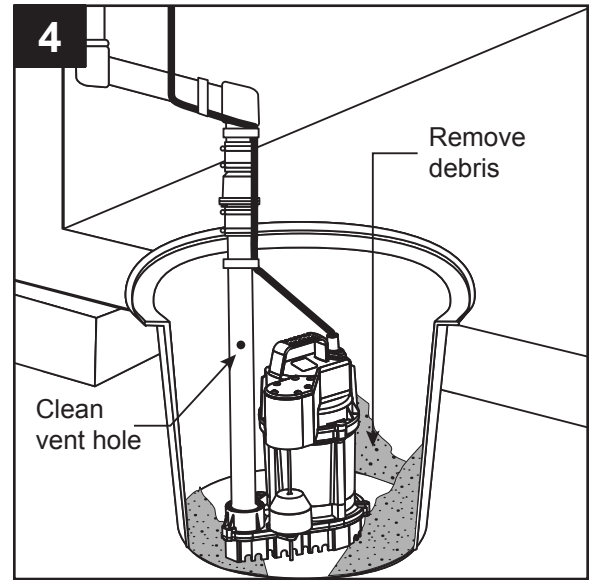

**NOTE:** If the sump basin is larger than 18-in. diameter, the DC pump can be installed with the primary pump on the same level or slightly higher than the primary pump. If the sump basin is smaller than 18-in. diameter, the DC pump will be installed above the primary sump pump.

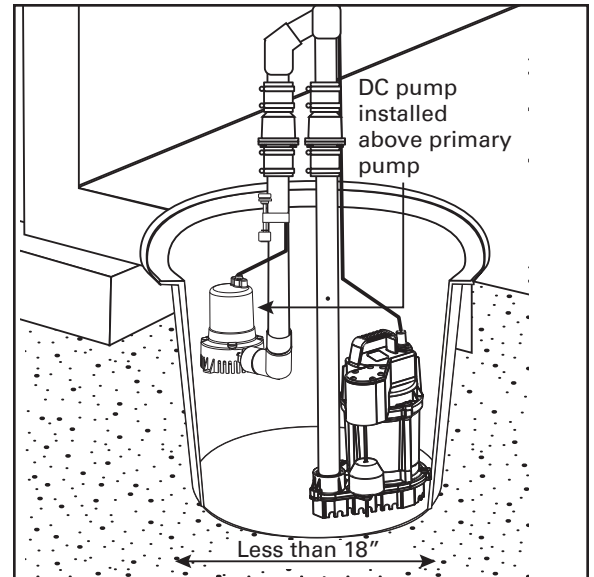

5. Disconnect or cut the main discharge pipe and separate the primary sump pump from the discharge pipe. Remove the pump from the sump basin.

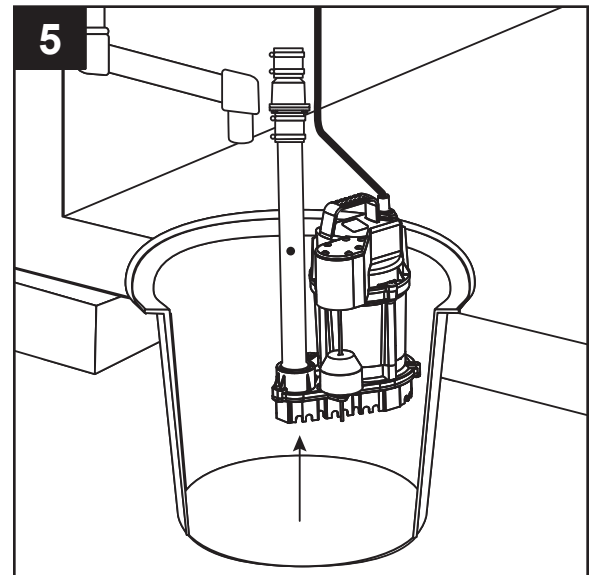

## INSTALLATION INSTRUCTIONS

6. Wrap the DC pump discharge thread with Teflon tape and attach a 1-1/4-in. FPT 90° elbow to the discharge.

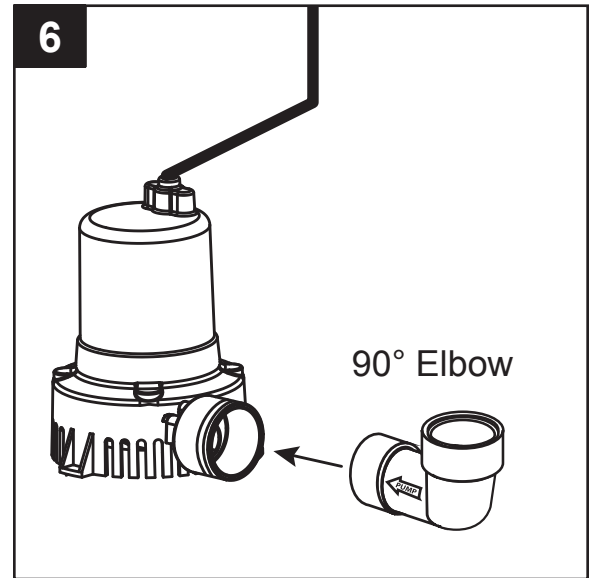

7. Wrap the thread of a 1-1/4-in. to 1-1/2-in adapter (not included) with Teflon tape and attach the adapter to the 90° elbow.

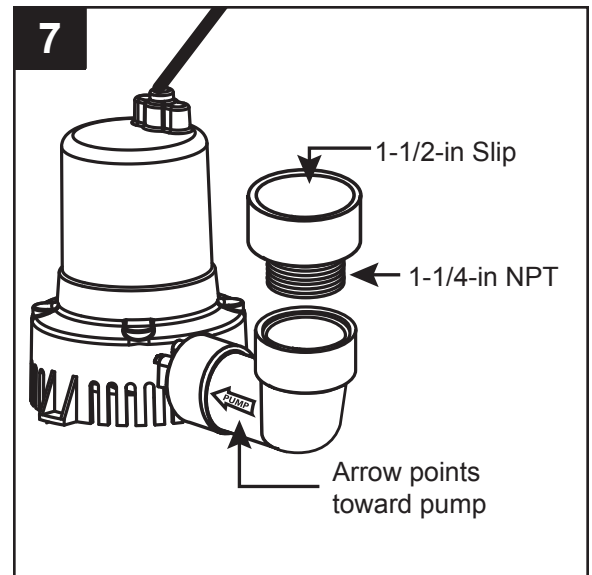

8. Install a "Y" pipe between the backup pump discharge pipe and the primary pump discharge

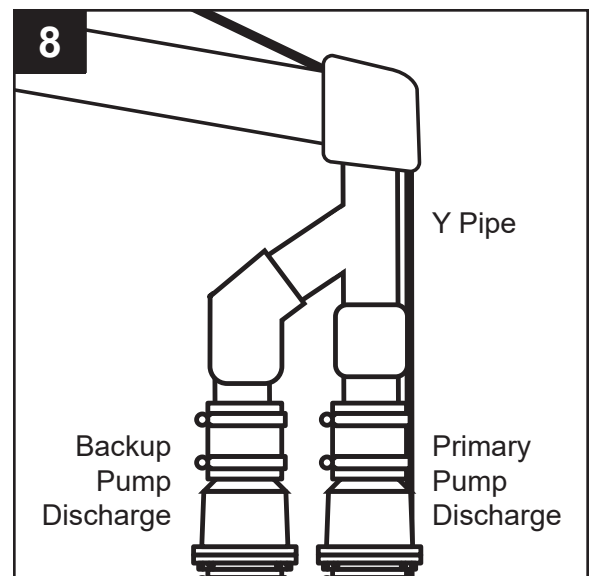

## INSTALLATION INSTRUCTIONS

**NOTE:** Assemble pipe and fittings without glue to check for proper fit.

9. Connect pumps, pipe, check valve and fittings to verify the position in the sump pit. Once fitting is correct, glue all joints using 2-step PVC glue and primer.

Both the primary pump and DC backup pumps will require check valves in the discharge pipes for proper operation. BOTH check valves should be located between pump discharge and where the discharge pipes are joined.

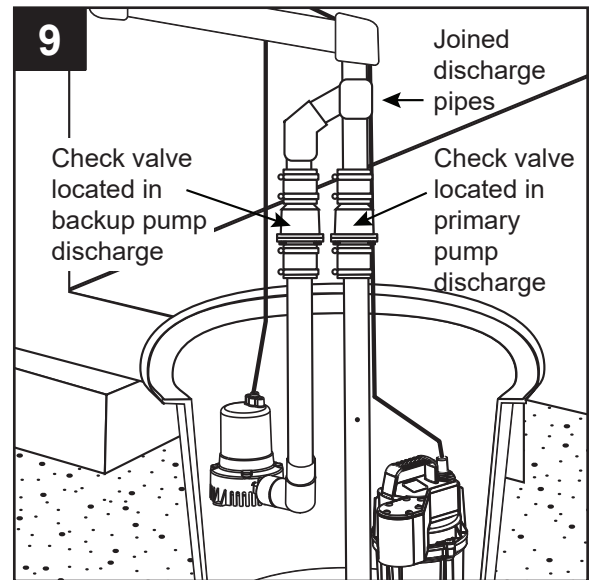

10. Loosely attach the DC pump switch clamp to the DC pump discharge pipe. Slide the switch mounting bracket under the switch clamp. Adjust the position of the switch so that the 'ON' level of the DC pump is above the 'ON' level of the primary pump. Tighten the mounting clamp of the DC pump switch in the correct location.

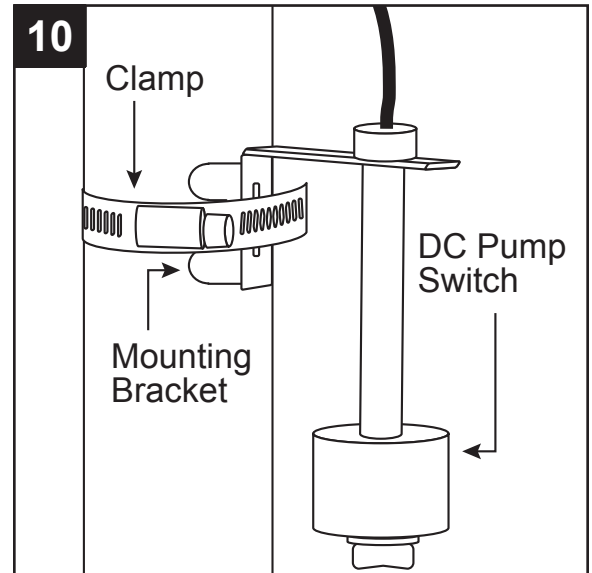

11. Place a fully-charged, deep-cycle marine battery inside the battery box. Connect the leads inside the battery box from the controller to the battery:  
**WARNING: Connecting the wires to the wrong terminals on the battery may cause damage to the controller.**

Red (+) to battery Red (+)  
Black (-) to battery Black (-)

**NOTE: The alarm will sound after connecting the battery. It will continue to sound until all connections are made and the float switch is in the down position.**

**NOTE:** Be sure the battery box ventilation holes are unobstructed. Battery control box must be set up in a well-ventilated area, away from any smoke, flames or pilot lights.

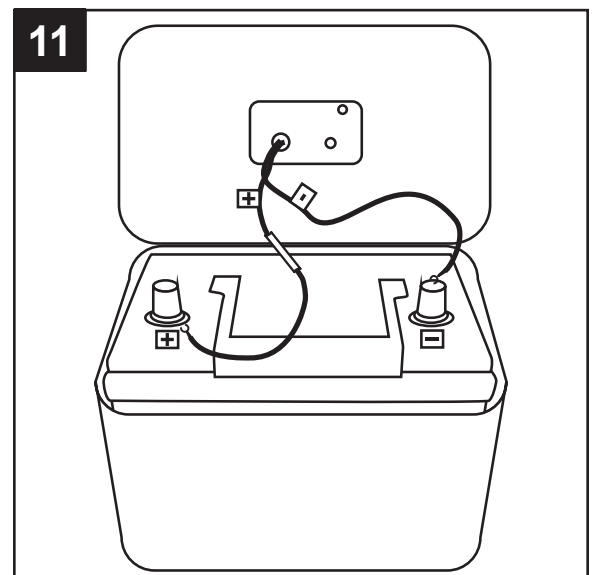



## INSTALLATION INSTRUCTIONS

12. Connect system wires to the controller on the top of the battery box lid.
- Plug the pump wire into the port marked 'PUMP'.
  - Plug the float switch wire into the port marked 'FLOAT'.
  - Plug the 12V charger into the port marked 'ADAPTER'. Plug the charger into a 115V GFCI protected power source.
- Once the charger is plugged in, the LED lights on the battery box should turn on.

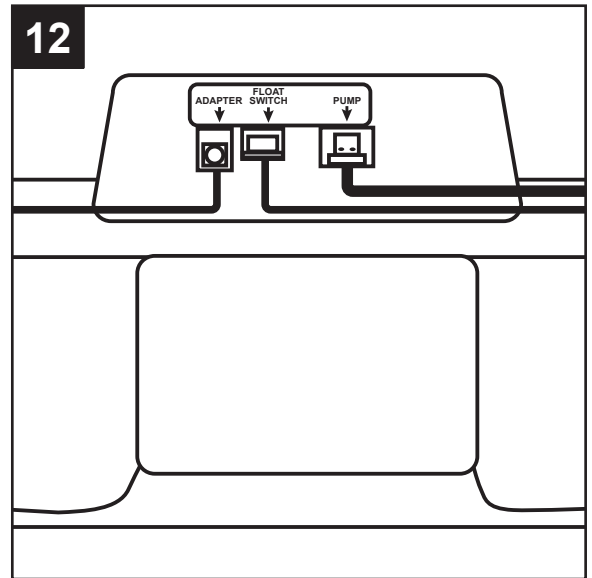

13. Test DC pump operation by lifting up the DC float switch and holding it in place. The pump 'Pump Status' LED will show a continuous light and the alarm will beep steadily. The pump should start at this time. If it doesn't start, check all connections.

NOTE: The pump will continue to run for an additional 10 seconds after the float has been lowered. The alarm will continue to sound while the pump is working.

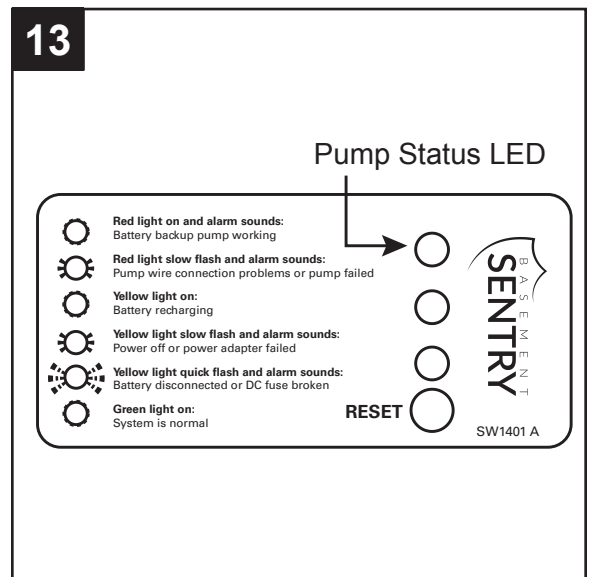

14. Test all system connections by pressing the 'RESET' button for 1 - 4 seconds. The alarm will sound. This will cause the system to run a self-test and the DC pump will run for 3 seconds.

To silence the alarm, press the 'RESET' button, hold for 4 - 8 seconds and release. The alarm should stop.

After the system returns to normal status, the alarm will automatically reset.

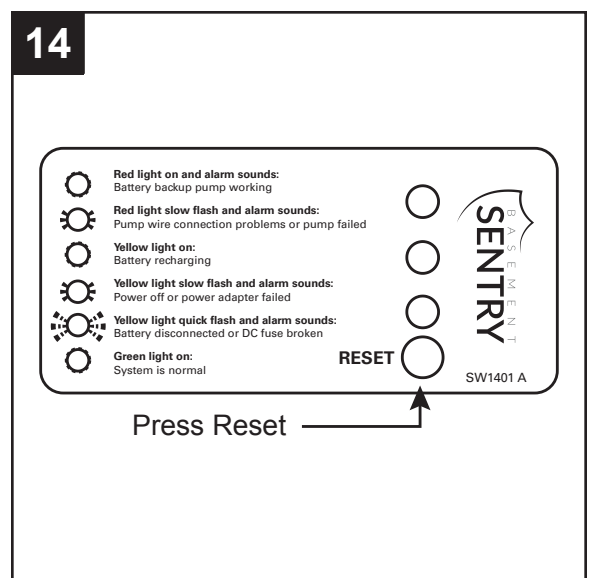

## INSTALLATION INSTRUCTIONS

### 15. LED Indicator Lights

Red light on and alarm sounds:

Battery backup pump is working

Red light slow flash and alarm sounds:

Pump wire connection problems or pump failure

Yellow light on:

Battery is recharging

Yellow light slow flash and alarm sounds:

Power off or power adapter failure

Yellow light quick flash and alarm sounds:

Battery is disconnected or DC fuse broken

Green light on:

The system is normal

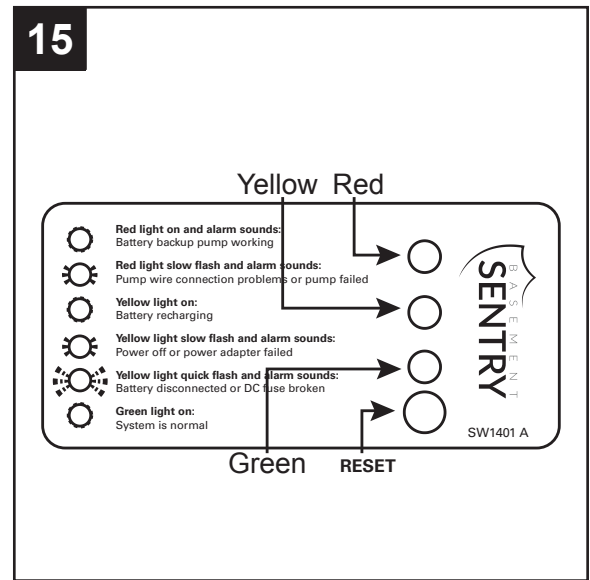

## OPERATION

NOTE: Sump basin must be filled with water before operation. Running the pump dry will cause damage and void the warranty.

1. Verify 115V pump operation by filling the basin with enough water to raise the float on the primary sump pump. Pump should start and remove water.

Unplug the 115V from the power source.

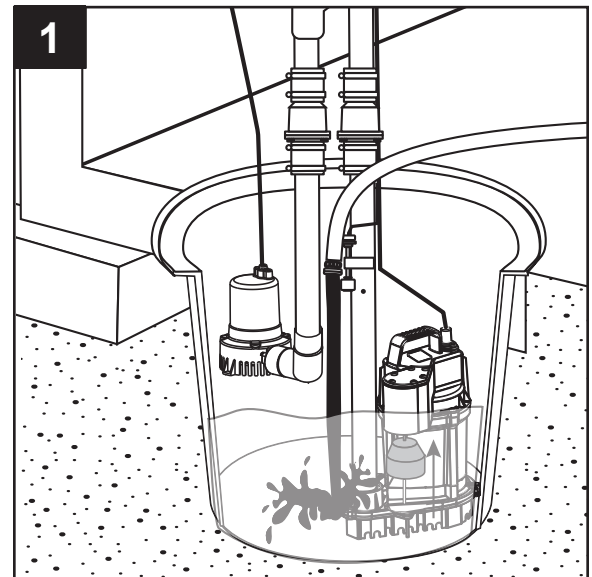

2. Test DC pump operation by refilling the sump basin with water until the DC pump float moves to the top of the float rod.

The DC pump should start and pump water out of the sump basin. If pump does not operate, check all wire connections.

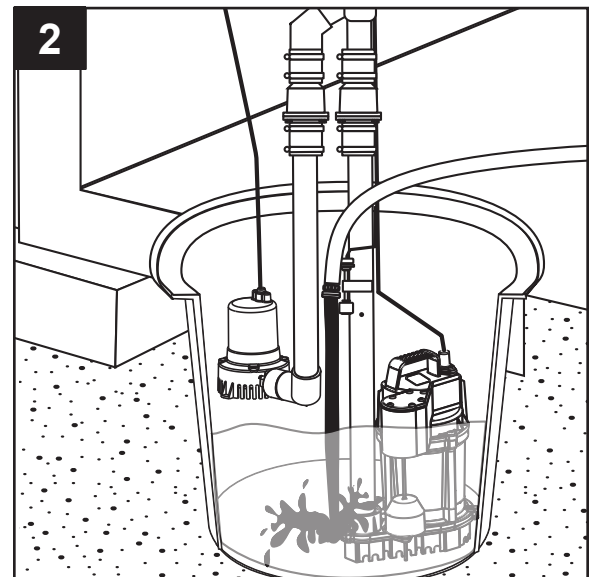

## CARE AND MAINTENANCE

**WARNING:** Always disconnect pump from power source before handling.

### Once a month:

Press the reset button for 1-3 seconds to run a self-test.

### At least every three months:

- Remove any debris that may build up in the sump basin to prevent it from interfering with the operation of the float switch.
- Clean out the vent hole in the discharge pipe.
- Test system for operation.

Follow the battery manufacturer's recommendations for maintenance and safe use of the battery. Replace battery as needed.

**WARNING:** An acid-filled standard lead-acid battery contains sulfuric acid. Avoid contact with skin, eyes or clothing.

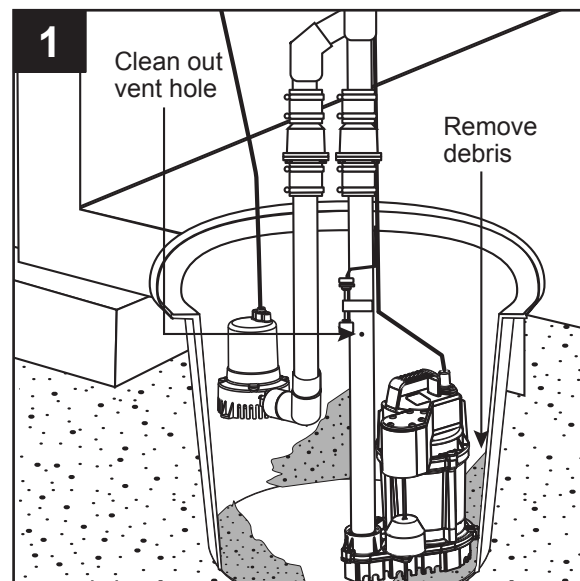

## WARRANTY

This product is warranted for one year from the date of purchase or two years from the date of manufacture, whichever occurs first. Subject to the conditions hereinafter set forth, the manufacturer will repair or replace to the original consumer, any portion of the product which proves defective due to defective materials or workmanship. This warranty does not cover replacement parts for failure due to normal wear and tear. To obtain warranty service, contact the retailer from whom the product was purchased. The manufacturer retains the sole right and option to determine whether to repair or replace defective equipment, parts or components. Damage due to conditions beyond the control of the manufacturer is not covered by this warranty. For warranty questions or service, call 1-800-742-5044.

THIS WARRANTY WILL NOT APPLY: (a) To defects or malfunctions resulting from failure to properly install, operate or maintain the unit in accordance with printed instructions provided; (b) to failures resulting from abuse, accident or negligence; (c) to normal maintenance services and the parts used in connection with such service; (d) to units which are not installed in accordance with normal applicable local codes, ordinances and good trade practices; and (e) the unit is used for purposes other than for what it was designed and manufactured.

RETURN OF WARRANTED COMPONENTS: Any item to be repaired or replaced under this warranty must be returned to the manufacturer at such place as the manufacturer may designate, freight prepaid.

THE WARRANTY PROVIDED HEREIN IS IN LIEU OF ALL OTHER EXPRESS WARRANTIES, AND MAY NOT BE EXTENDED OR MODIFIED BY ANYONE. ANY IMPLIED WARRANTIES SHALL BE LIMITED TO THE PERIOD OF THE LIMITED WARRANTY AND THEREAFTER ALL SUCH IMPLIED WARRANTIES ARE DISCLAIMED AND EXCLUDED. THE MANUFACTURER SHALL NOT, UNDER ANY CIRCUMSTANCES, BE LIABLE FOR INCIDENTAL, CONSEQUENTIAL OR SPECIAL DAMAGES, SUCH AS, BUT NOT LIMITED TO DAMAGE TO, OR LOSS OF, OTHER PROPERTY OR EQUIPMENT, LOSS OF PROFITS, INCONVENIENCE, OR OTHER INCIDENTAL OR CONSEQUENTIAL DAMAGES OF ANY TYPE OR NATURE. THE LIABILITY OF THE MANUFACTURER SHALL NOT EXCEED THE PRICE OF THE PRODUCT UPON WHICH SUCH LIABILITY IS BASED.

This warranty gives you specific legal rights, and you may have other rights which vary from state to state. Some states do not allow limitations on duration of implied warranties or exclusion of incidental or consequential damages, so the above limitations may not apply to you.

**In those instances where damages are incurred as a result of an alleged pump failure, the Homeowner must retain possession of the pump for investigation purposes.**

## TROUBLESHOOTING



**DANGER**

### RISK OF ELECTRIC SHOCK.

Always disconnect power source before attempting to install, service, or maintain the pump. Never handle a pump with wet hands or when standing on wet or damp surface or in water. Fatal electrical shock could occur.

PROBLEM	POSSIBLE CAUSE	CORRECTIVE ACTION
Pump will not start or run (Red light comes on briefly and shuts off)	1. Wire connection issues	1. Check all the wiring connections.
	2. Battery issue	2. Check for a low or defective battery. Replace if needed.
	3. Switch is stuck	3. Check to be sure the float switch is free to move up and down on the float switch rod.
	4. Debris in pump inlet	4. Check for obstructions in pump.
Motor hums but pump doesn't pump water	1. Battery issue	1. Check for a low or defective battery. Replace if needed.
Flow rate is too low	1. The discharge pipe length and/or height exceeds the capacity of the pump.	1. Re-configure the discharge pipe length or height to fit system specifications.
	2. Low battery	2. Replace the battery or charge the battery. It may take a few days to bring the voltage on the battery back up after heavy usage.
Pump cycles frequently	1. The check valve located between the discharge of the primary pump and the backup pump tee is not installed or is not working properly.	1. Install or replace check valve.
Pump runs but water level stays high	1. Battery issue	1. Check for a low or defective battery. Replace if needed.
	2. If power is restored to primary pump, pump may require service.	2. Check primary pump and service or replace as needed.
Slow flashing red light and alarm. Light and alarm will not clear when holding the reset button.	1. Pump wire connection	1. Check to make sure pump is properly plugged into the controller.
	2. Debris in impeller	2. Check if pump is moving water. Pump may be seized. Check for debris stuck in impeller.
	3. Pump Problem	3. Replace pump if pump is not moving water and no debris is interfering with impeller.
NOTE: Battery and wall adapter power must be removed to clear this fault.		















## INSTRUCCIONES DE INSTALACIÓN

- Envuelva la rosca de la descarga de la bomba de CC con cinta de teflón y acople un codo a 90° FTP de 3.2 cm (1-1/4 pulg.) a la descarga.

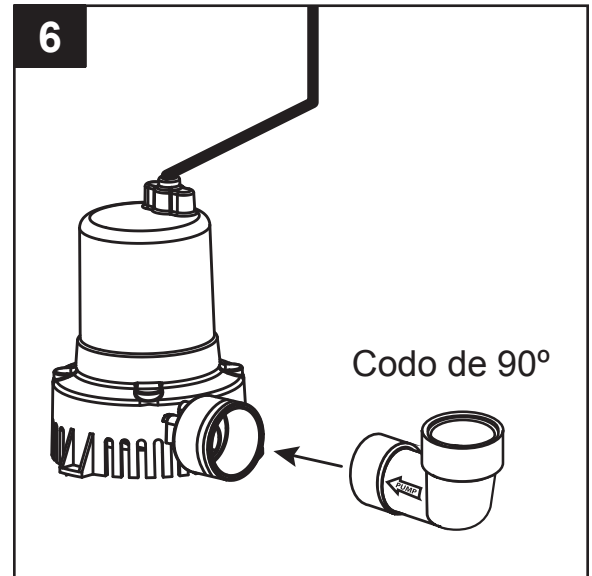

- Envuelva la rosca de un adaptador de 3.2 cm (1-1/4 pulg.) a 3.8 cm (1-1/2 pulg.) (no incluido) con cinta de teflón y acople el adaptador al codo a 90°.

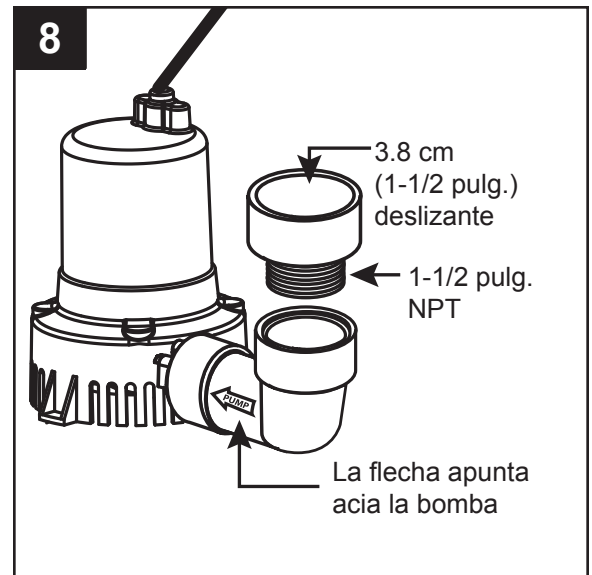

- Instale un tubo en "Y" entre la tubería de descarga de la bomba de respaldo y la descarga de la bomba principal.

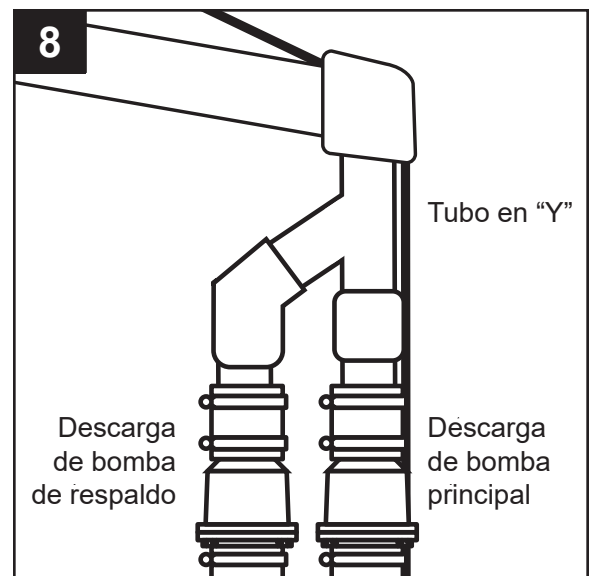

## INSTRUCCIONES DE INSTALACIÓN

NOTA: monte la tubería y los conectores sin pegamento para asegurarse de que encajen bien.

- Conecte las bombas, la tubería, la válvula de retención y los conectores para verificar la posición en la fosa del sumidero. Una vez que la conexión esté correcta, pegue todas las juntas usando el sistema para pegar y cebar PVC de 2 pasos.

Para que funcionen correctamente, tanto la bomba principal como las bombas de respaldo de CC requerirán válvulas de retención en las tuberías de descarga. Las DOS válvulas de retención deben estar entre la descarga de la bomba y donde se unen las pipas de descarga.

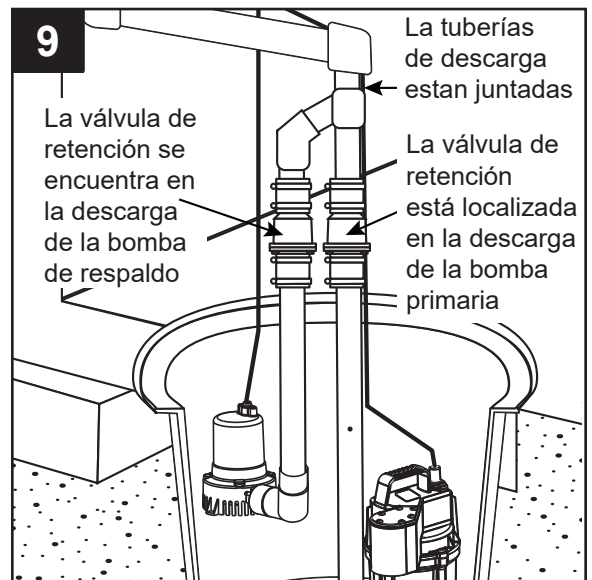

- Acople sin apretar la abrazadera del interruptor de la bomba de CC en la tubería de descarga de la bomba de CC. Deslice el soporte de montaje del interruptor por debajo de la abrazadera del interruptor. Ajuste la posición del interruptor para que el nivel de encendido (ON) de la bomba de CC esté por encima del nivel de encendido (ON) de la bomba principal. Apriete la abrazadera de montaje del interruptor de la bomba de CC en la ubicación correcta.

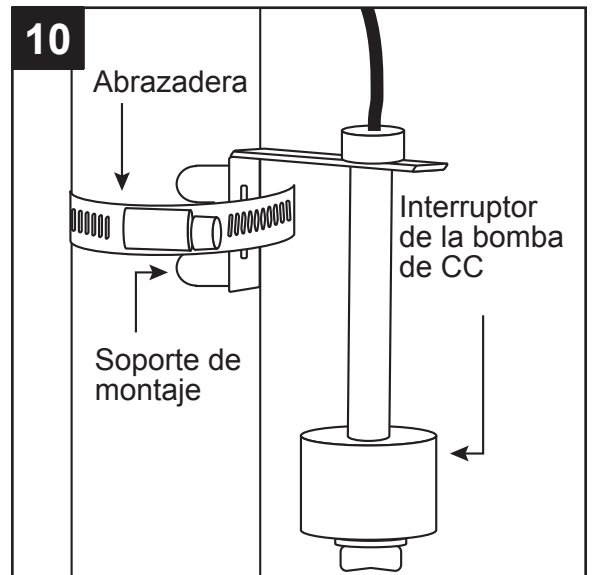

- Coloque una batería marina de ciclo profundo completamente cargada en el interior de la caja de la batería. Conecte los cables de la caja de la batería desde el controlador hasta la batería:  
**ADVERTENCIA: Conectar los cables a los terminales incorrectos de la batería puede dañar el controlador.**

Rojo (+) a Rojo de la batería (+)  
Negro (-) a Negro de la batería (-)

**NOTA: la alarma sonará tras conectar la batería. Continuará sonando hasta que se hayan realizado todas las conexiones y el interruptor de flotador esté en la posición de abajo.**

NOTA: asegúrese de que los orificios de ventilación de la caja de la batería no estén obstruidos. La caja de control de la batería debe colocarse en un área bien ventilada, apartada de cualquier tipo de humo, llamas o luces piloto.

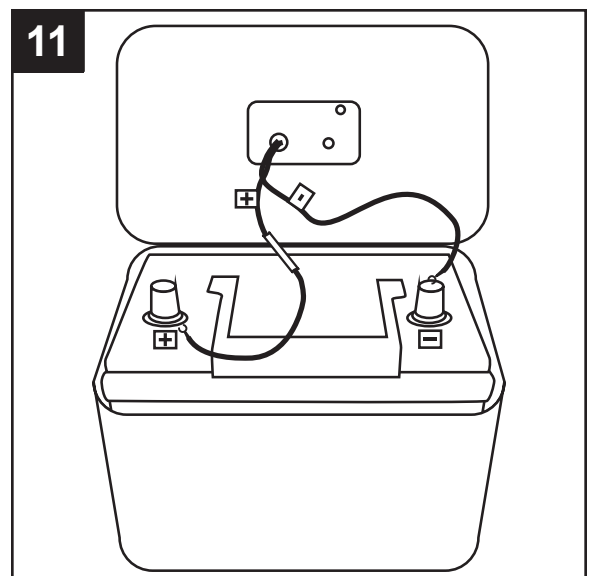

## INSTRUCCIONES DE INSTALACIÓN

12. Conecte los cables del sistema al controlador en la parte superior de la tapa de la caja de la batería.
- Enchufe el cable de la bomba en el puerto marcado como "PUMP" (bomba).
  - Enchufe el cable del interruptor de flotador en el puerto marcado como "FLOAT" (flotador).
  - Enchufe el cargador de 12 V en el puerto marcado como "ADAPTER" (adaptador). Enchufe el cargador en una fuente de alimentación de 115 V protegida por GFCI.

Una vez que el cargador esté enchufado, las luces LED de la caja de la batería deberían encenderse.

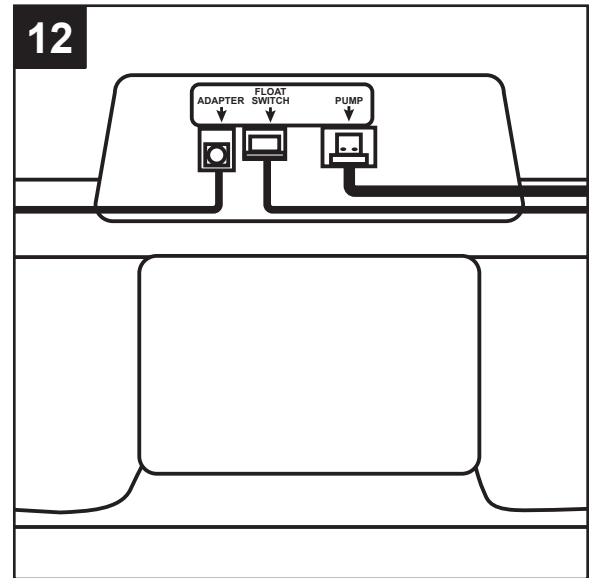

13. Compruebe el funcionamiento de la bomba de CC llenando el interruptor de flotador de CC y manteniéndolo en su lugar. El LED de estado de la bomba estará continuamente iluminado y la alarma pitará de forma constante. La bomba debería arrancar en este momento. Si no arranca, compruebe todas las conexiones.

NOTA: La bomba continuará funcionando durante 10 segundos adicionales una vez que el flotador haya descendido. La alarma continuará sonando mientras la bomba esté en funcionamiento.

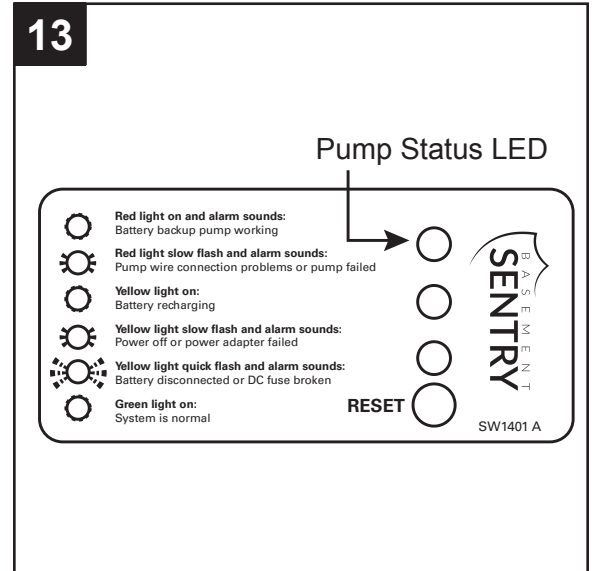

14. Compruebe todas las conexiones del sistema presionando el botón "RESET" (restablecer) durante 1 a 4 segundos. Sonará la alarma. Esto provocará que el sistema realice una autocomprobación y la bomba de CC funcionará durante 3 segundos.

Para silenciar una alarma activa, presione el botón "RESET", manténgalo oprimido durante 4 a 8 segundos y suéltelo. La alarma debería detenerse. Después de que el sistema regrese al estado normal, la alarma se restablecerá automáticamente.

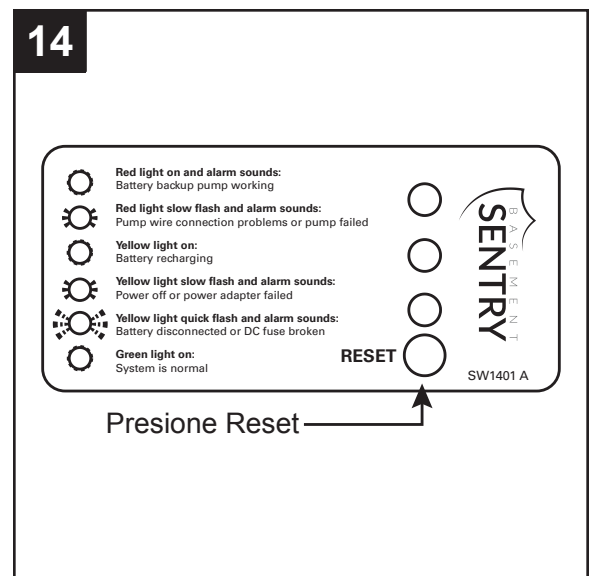

## INSTRUCCIONES DE INSTALACIÓN

### 15. Luces indicadoras LED

#### Luz verde encendida:

el sistema está normal.

#### Parpadeo rápido de la luz amarilla y la alarma suena:

la batería está desconectada o el fusible de CC está roto

#### Parpadeo lento de la luz amarilla y la alarma suena:

la energía está apagada o falla del adaptador de energía

#### Luz amarilla encendida:

la batería se está recargando

#### Luz roja encendida y la alarma suena:

la bomba con batería de reserva está funcionando

#### Parpadeo lento de la luz roja y la alarma suena:

Problemas con la conexión de los cables de la bomba o falla de la bomba

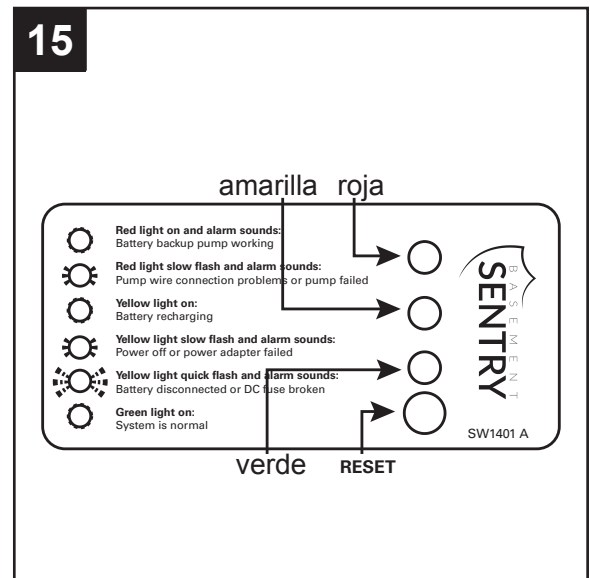

## OPERACIÓN

NOTA: el contenedor para agua de sumidero debe llenarse con agua antes del funcionamiento. Operar la bomba en seco provocará daños y anulará la garantía.

1. Verifique el funcionamiento de la bomba de 115 V llenando el contenedor con suficiente agua para levantar el flotador de la bomba de sumidero principal. La bomba debería arrancar y sacar agua. Desconecte el de 115 V de la toma de corriente.

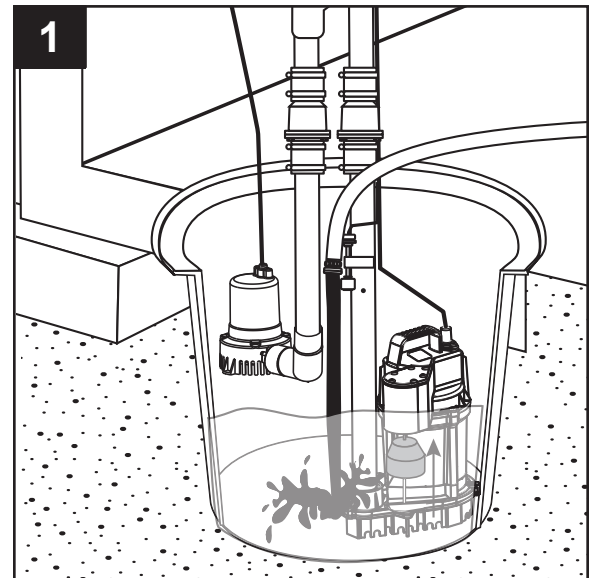

2. Compruebe el funcionamiento de la bomba de CC rellenando el contenedor para agua de sumidero con agua hasta que el flotador de la bomba de CC se mueva hasta la parte superior de la varilla del flotador.

La bomba de CC debería arrancar y bombear agua del contenedor para agua de sumidero. Si la bomba no funciona, compruebe todas las conexiones de cables.

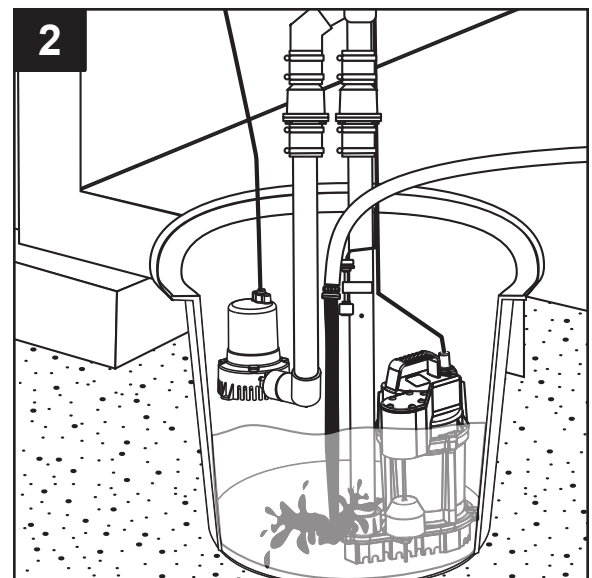

## CUIDADO Y MANTENIMIENTO

**ADVERTENCIA:** desconecte siempre la bomba de su fuente de alimentación antes de manipularla.

### Una vez al mez:

Presione el botón de reinicio por 1-3 segundos para ejecutar un autotest

### Al menos cada tres meses:

- Quite la suciedad que pudiera acumularse alrededor del contenedor para agua de sumidero para evitar que interfiera con el funcionamiento del interruptor del flotador.
- Limpie el orificio de ventilación de la tubería de descarga.
- Pruebe el funcionamiento del sistema.

Siga las recomendaciones del fabricante de la batería en cuanto al mantenimiento y uso seguro de la batería. Reemplace la batería si es necesario.

**ADVERTENCIA:** una batería estándar de plomo-ácido llena de ácido contiene ácido sulfúrico. Evite el contacto con la piel, los ojos o la ropa.

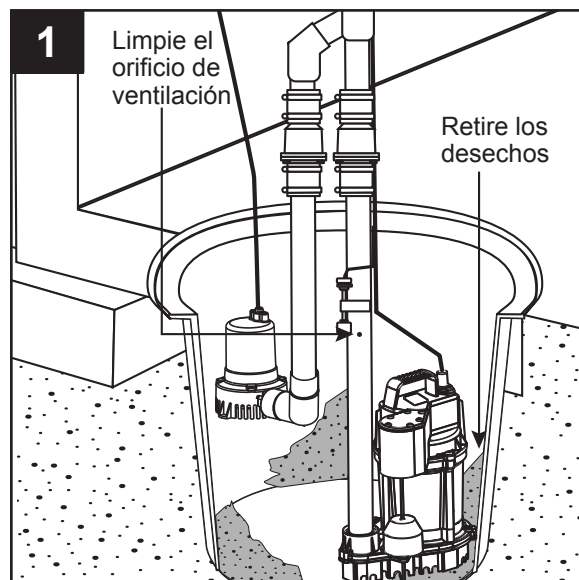

## GARANTÍA

Este producto cuenta con una garantía de dos años a partir de la fecha de compra o treinta (30) meses a partir de la fecha de fabricación, lo que ocurra primero. Sujeto a las condiciones establecidas en el presente, el fabricante reparará o reemplazará, para el consumidor original, cualquier parte del producto que se compruebe que está defectuosa debido a defectos en los materiales o la mano de obra. Esta garantía no cubre las piezas de repuesto por falla debido a desgaste normal. Para obtener los servicios de garantía, póngase en contacto con el vendedor minorista donde adquirió el producto. El fabricante se reserva el derecho y la opción exclusivos de determinar la reparación o el reemplazo de equipos, piezas o componentes defectuosos. Los daños causados por condiciones que escapen del control del fabricante no están cubiertos por esta garantía. Para realizar preguntas u obtener el servicio de garantía, llame al 1-800-742-5044.

ESTA GARANTÍA NO SE APLICARÁ: (a) a defectos o mal funcionamiento como resultado de una falla en la instalación, operación o mantenimiento de la unidad según lo indicado en las instrucciones impresas provistas; (b) a fallas resultantes debido al mal uso, accidente o negligencia; (c) a los servicios de mantenimiento normativos y las piezas utilizadas en conexión con dichos servicios; (d) a unidades que no se instalaron según los códigos normativos locales, las ordenanzas o las buenas prácticas comerciales aplicables; y (e) si la unidad se utiliza para fines para los cuales no está destinada ni fabricada.

DEVOLUCIÓN DE LOS COMPONENTES EN GARANTÍA: cualquier artículo a reparar o reemplazar bajo esta garantía debe devolverse al fabricante al lugar designado por este, con flete prepago.

LA GARANTÍA QUE SE PROPORCIONA EN EL PRESENTE REEMPLAZA A TODAS LAS DEMÁS GARANTÍAS EXPLÍCITAS Y NO PUEDE SER EXTENDIDA NI MODIFICADA POR NADIE. CUALQUIER GARANTÍA IMPLÍCITA ESTARÁ LIMITADA AL PERÍODO DE LA GARANTÍA LIMITADA Y, POR CONSIGUIENTE, SE RECHAZAN Y SE EXCLUYEN TODAS DICHAS GARANTÍAS IMPLÍCITAS. BAJO NINGUNA CIRCUNSTANCIA, EL FABRICANTE SERÁ RESPONSABLE DE DAÑOS ACCIDENTALES, RESULTANTES O ESPECIALES, INCLUIDOS, ENTRE OTROS, LOS DAÑOS A LA PROPIEDAD O AL EQUIPO, O LA PÉRDIDA DE ESTOS, LA PÉRDIDA DE GANANCIAS, INCONVENIENTES U OTROS DAÑOS ACCIDENTALES O RESULTANTES DE CUALQUIER TIPO O NATURALEZA. LA RESPONSABILIDAD DEL FABRICANTE NO SUPERARÁ EL PRECIO DEL PRODUCTO SOBRE EL CUAL SE BASA DICHA RESPONSABILIDAD.

Esta garantía le otorga derechos legales específicos, pero usted podría tener otros derechos que varían según el estado. Algunos estados no permiten las limitaciones sobre la duración de las garantías implícitas, o la exclusión de los daños accidentales o resultantes, de modo que las limitaciones mencionadas anteriormente podrían no aplicarse en su caso.

**En aquellas instancias en que haya daños causados por una presunta falla de la bomba, el propietario deberá conservar la bomba a fin de investigar dicha falla.**

## SOLUCIÓN DE PROBLEMAS



### PELIGRO

#### RIESGO DE CHOQUE ELÉCTRICO.

Desconecte siempre la fuente de alimentación antes de intentar instalar, reparar o realizarle mantenimiento a la bomba. Nunca manipule una bomba con las manos mojadas ni cuando esté parado sobre una superficie húmeda o en el agua. Podría ocurrir una descarga eléctrica fatal.

PROBLEMA	CAUSAS POSIBLES	ACCIÓN CORRECTIVA
La bomba no arranca o no funciona (La luz roja se enciende brevemente y se apaga)	1. Problemas de conexión de cables	1. Verifique todas las conexiones de cables.
	2. Problema con la batería	2. Verifique si la batería tiene poca carga o está defectuosa. Reemplace si es necesario.
	3. Interruptor atascado	3. Asegúrese de que el interruptor de flotador pueda moverse libremente hacia arriba y hacia abajo por la varilla del interruptor de flotador.
	4. Suciedad en la entrada de la bomba	4. Compruebe si hay obstrucciones en la bomba.
El motor suena pero la bomba no bombea agua	1. Problema con la batería	1. Verifique si la batería tiene poca carga o está defectuosa. Reemplace si es necesario.
El caudal es demasiado bajo	1. La longitud y/o la altura de la tubería de descarga superan la capacidad de la bomba.	1. Reconfigure la longitud o la altura de la tubería de descarga para adaptarse a las especificaciones del sistema.
	2. Batería baja	2. Reemplace la batería o cargue la batería. Puede llevar algunos días recuperar el voltaje de la batería después de un uso intensivo.
La bomba se enciende y se apaga con frecuencia	1. La válvula de retención situada entre la descarga de la bomba principal y la T de la bomba de respaldo no está instalada o no está funcionando bien.	1. Instale o reemplace la válvula de retención.
La bomba funciona pero el nivel de agua se mantiene alto	1. Problema con la batería	1. Verifique si la batería tiene poca carga o está defectuosa. Reemplace si es necesario.
	2. Si se restablece la energía a la bomba principal, es posible que la bomba necesite mantenimiento.	2. Verifique la bomba principal y realice el mantenimiento o reemplácela, según sea necesario.
Parpadeo lento de luz roja y alarma. La luz y la alarma no se desactivarán al mantener presionado el botón de reinicio.	1. Conexión del cable de la bomba	1. Verifique que la bomba esté conectada correctamente al controlador.
	2. Suciedad en el impulsor	2. Compruebe si la bomba está moviendo agua. La bomba puede detenerse. Verifique que no haya residuos atascados en el impulsor.
	3. Problema de la bomba	3. Reemplace la bomba si la bomba no mueve agua y no hay residuos que interfieran con el impulsor.
NOTA: El adaptador de pared y la batería deben ser eliminadas para eliminar esta falla.		